

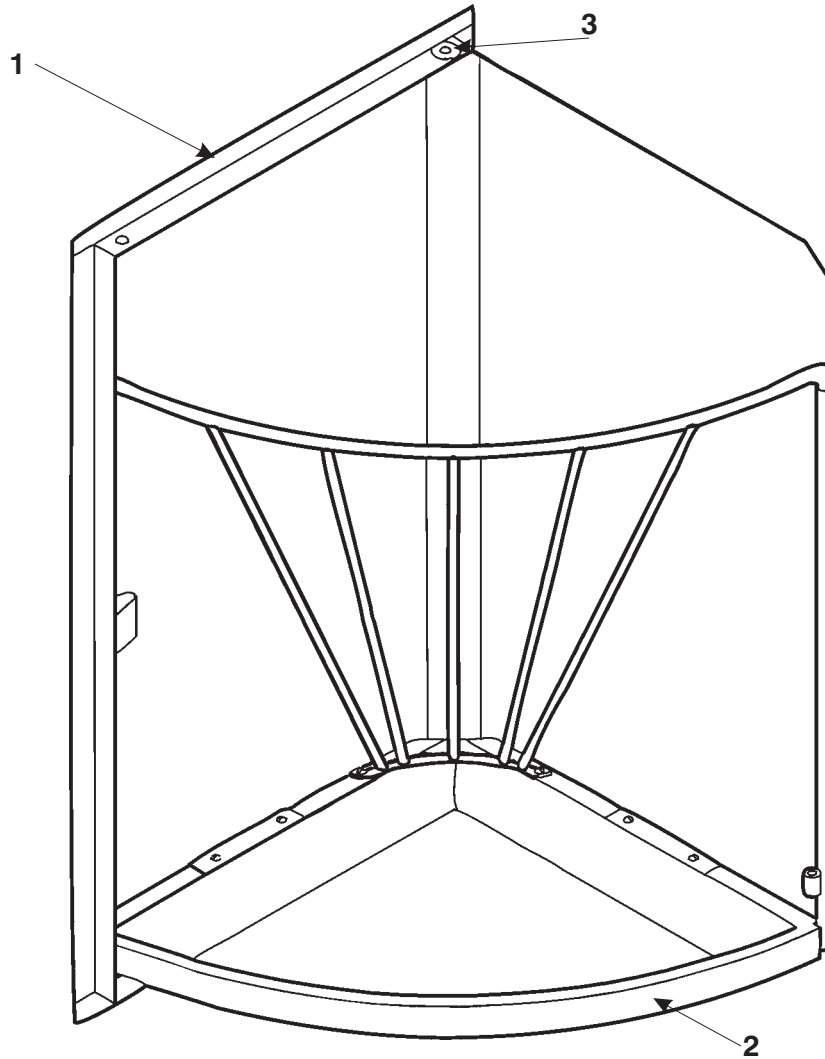
# ASSEMBLY INSTRUCTIONS

## Swing Out Corner Feeder (HFCS) 76110138

Hardware Pkg.  
76900158

THANK YOU FOR PURCHASING THIS PRODUCT

For questions about this product, or parts inquiries, please contact our Customer Service Center listed below.



This feeder is designed to speed up and simplify feeding. All exposed edges on the feeder are rounded to prevent injury to you and your horse. Each feeder can be mounted to swing left or right.

### **FEATURES INCLUDE:**

- (A) Solid rod construction
- (B) Aisle side of feeder flush with wall
- (C) Easy open spring latch
- (D) Rounded corners to prevent injuries
- (E) One-piece back, no welding
- (F) Poly feed tray prevents rust and has rounded edges

**Behlen  
COUNTRY**

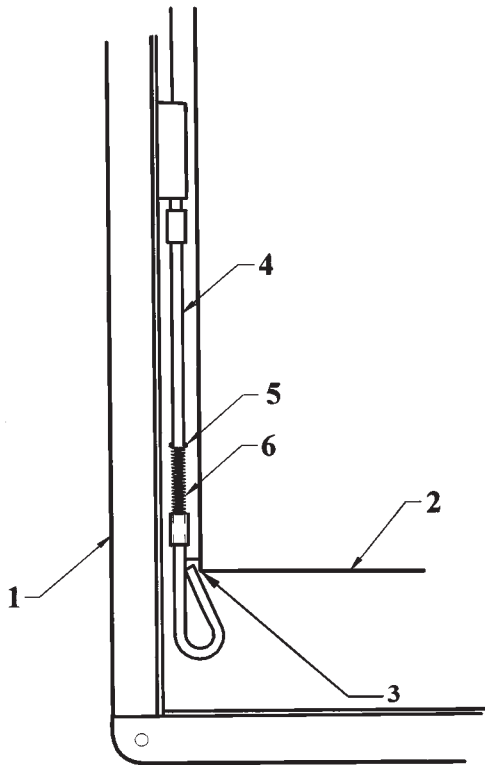
### **CUSTOMER SERVICE CENTER**

PO Box 569  
Columbus, NE  
68602-0569

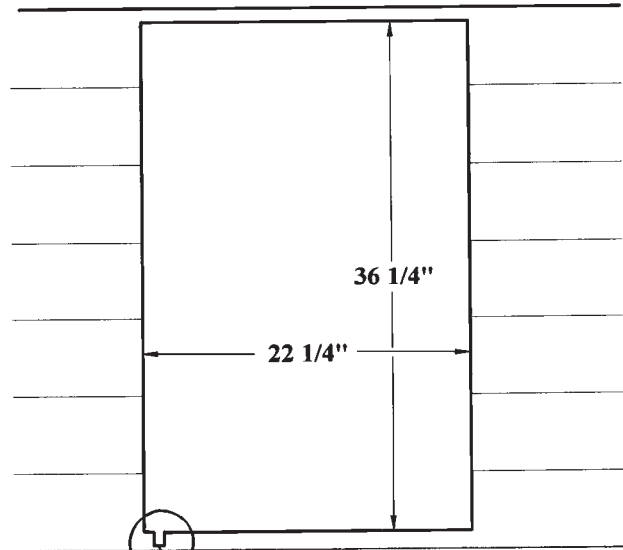
Ph: 1-800-447-2751  
Fax: (402) 563-7447  
www.behlencountry.com

# ASSEMBLY INSTRUCTIONS

1. The feeder has been assembled with right hand opening. If left hand opening is required, remove pivot rod, rotate frame 180° and reinstall pivot rod. Move latch assembly to other side of feeder so it will latch. (See Fig. 1)

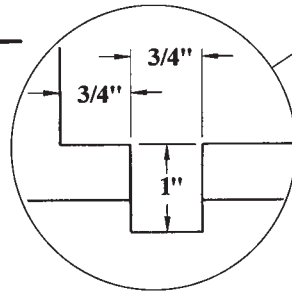


**Fig. 1**



**NOTE:** a notch will need to be cut on the pivot side.

**Fig. 2**



3. Cut frame opening into wall. Wall opening size required is 36-1/4" high x 22-1/4" wide.  
*NOTICE.* A notch will need to be cut on pivot side of opening for the pivot rod (See Fig. 2)
4. Fasten feeder and frame to wall with lags or bolts (not provided).

## PARTS LISTING

ITEM	DESCRIPTION	PART NO	QTY.
1	Frame Weldment	76400048	1
2	Swing Out Corner Feeder	76410178	1
3	Rod Pivot Weldment	76400089	1
4	Rod, Latch	76601968	1
5	*3/32" x 1/2" Cotter Pin z.p.	—	1
6	Spring, Compression	3428076	1
•	1/2" Std. Washer z.p.	—	2

\*Standard Hardware Items. May be purchased locally.

•Not illustrated.